

Pin NO.	Signal Assignment
# 1	VBUS
# 2	D-
# 3	D+
# 4	PGND
# 5	SSRX-
# 6	SSRX+
# 7	GND
# 8	SSTX-
# 9	SSTX+

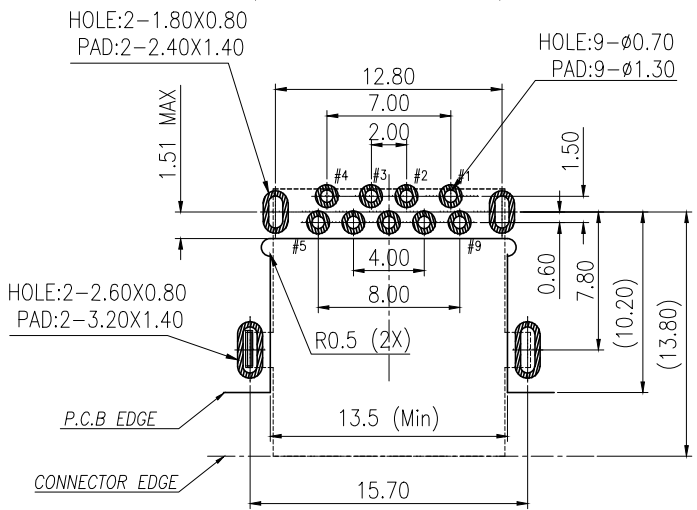
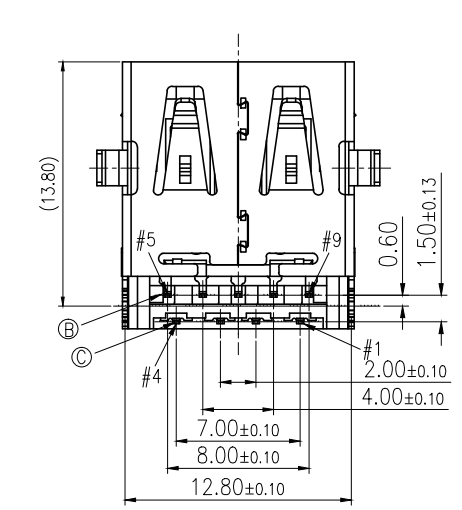

Recommended P.C.B Layout (THK:1.0mm)
Top View (Tot:±0.05)

SPECIFICATIONS:

- ELECTRICAL CHARACTERISTICS:
 - CURRENT RATING: 1.8A (PIN1,4) ; OTHER CONTACTS 0.25A
 - CONTACT RESISTANCE: 50mΩ MAX.INITIAL.
 - DIELECTRIC WITHSTANDING VOLTAGE: 100V AC FOR 1 MINUTE
 - INSULATION RESISTANCE: 100 MEGOHMS BY 500V DC.
- MECHANICAL CHARACTERISTICS:
 - INSERTION FORCE : 3.5 Kgf MAX.
 - WITHDRAWAL FORCE : 1.02 Kgf MIN.
- DURABILITY: 5,000 CYCLES,
- OTHER SPEC TO REFER USB 3.0 SPEC.
- TO CONFORM TO SINGATRON HAZARDOUS SUBSTANCE FREE SPEC.
- HALOGEN FREE PRODUCT IDENTIFICATION MARK : Ⓢ
- HALOGEN FREE PRODUCT IDENTIFICATION LABEL ON PACKAGING:
- FOR REFLOW SOLDERING LEAD-FREE PROCESS.
- PACKAGING : TAPE & REEL.

D	SHELL	1	STAINLESS STEEL	NICKEL 60u"MIN
C	4P TERMINAL	4	COPPER ALLOY	Au 2u" AND Pd/Ni 30u" ON CONTACT AREA ,TIN 60u"MIN. ON SOLDER TAIL,ALL OVER 80u" NICKEL PLATED
B	5P TERMINAL	5	COPPER ALLOY	
A	HOUSING	1	PA-IOT Vicnyl R630RH	BLACK
NO	DESCRIPTION	QTY	MATERIAL	PLATING & COLOR
UNLESS OTHERWISE SPECIFIED TOLERANCES		Singatron Enterprise Co., Ltd. 信音企業股份有限公司		
DECIMALS: ANGLES:		TITLE: USB3.0 REVERSE CONNECTOR		
X	:±0.5	X	:±2°	DWN peng PART NO. 2UB2308-006211F
X.X	:±0.3	X.X	:±1°	CHKD james SCALE 4:1 UNIT: mm
X.XX	:±0.2			APVD boye SIZE: A3 SHEET:1 OF 1 REV: B
CUSTOMER COPY				